

The James Webb Space Telescope: Why space telescopes are important

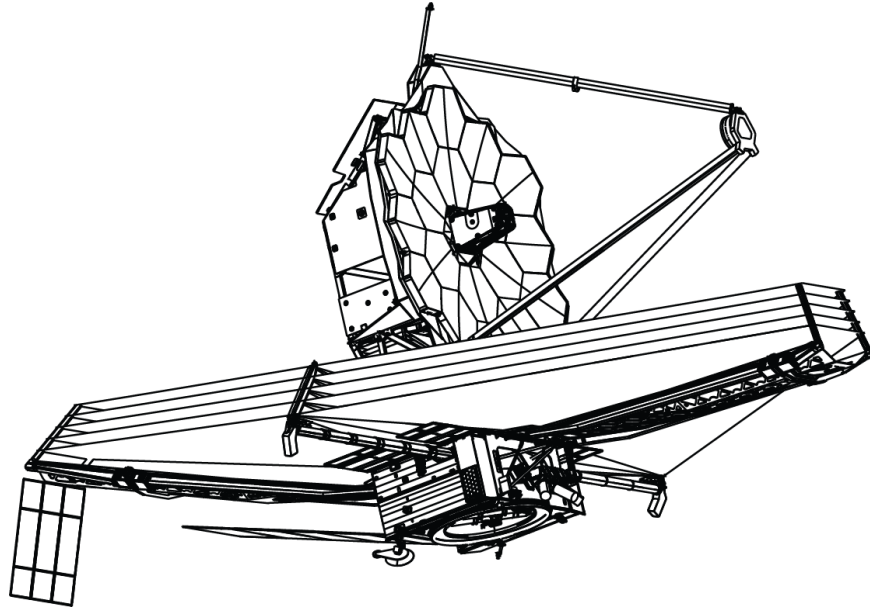

Credit: Illustration courtesy of NASA

Grade Level: 6 to 8

Lesson Duration: 2 x 50 minute periods

Rationale: Later this decade, the James Webb Space Telescope (Webb) will launch from Earth to unlock some of the most thought provoking questions of our time. Webb is the successor of the Hubble Space Telescope (Hubble), stands 3 stories high and spans the size of a tennis court. This gargantuan telescope will reside 1-million miles from our planet; this is nearly 4 times the distance from the Earth to the Moon. Webb will study the formation of galaxies, planets outside of our Solar System, and newborn stars, by using the infrared part of the Electromagnetic Spectrum. The 6.5 meter segmented mirror of Webb has a light-gathering power of 7 times that of Hubble. To give students a perspective on the need for large space-based telescopes, students will explore why these types of telescopes are necessary, and students will work together to construct scale models of the Hubble and Webb mirrors. This multi-disciplinary lesson will cover topics in art, science, and technology.

Key Concepts: The importance of large space telescopes and perspective

Content Standards:

National Science Education Standards (1996: Grades 5-8)

- A: Abilities of Technological Design
 - Implement a proposed design
- F: Science in Personal and Social Perspectives
 - Science and technology in society

International Society for Technology in Education Standards (2007: Grades K-12)

- 1: Creativity and Innovation
 - B: Create original works as a means of personal or group expression
 - C: Use models and simulations to explore complex systems and issues

National Standards for Visual Art (1994: Grades 5-8)

- 5: Reflecting upon and assessing the characteristics and merits of their work and the work of others
 - Students compare multiple purposes for creating works of art
- 6: Making connections between visual arts and other disciplines
 - Students describe ways in which the principles and subject matter of other disciplines taught in school are interrelated with the visual arts

Learning Outcomes:

- Students will *describe* why space-based telescopes are important.
- Students will, as a class, *create* scale models of the Webb and Hubble primary mirror and an artistic representation of a galaxy on the reverse side of each model.
- Students will *compare* each mirror model and each galaxy representation. Students will additionally *reflect* on what differences exist between each model and how subjects like art and science can be interrelated.

Instructional Procedure:

1. Begin the lesson by having students take out their science journals. Ask students “*Why are telescopes important?*” and “*Why do we need a space telescope as opposed to a ground-based telescope?*” Allow them time to write their responses in their journal. Have students pair up and ask them to share their responses with a classmate and then share with the class.
2. Have students gather around a window in the classroom or in the school. Spray the window with water by using a water mister. Guide students’ understanding using an analogy that this window represents the Earth’s atmosphere. Have students focus their sight on a distant object on the other side of the glass. Ask them to describe the appearance of the object in as much detail as possible, and to discuss some of the challenges they face in viewing the object. Have them record these responses in their journal.
3. Repeat step 2, but this time have the students look at the same object through the window with a set of binoculars or a small telescope mounted on a tripod. Ask them to again describe the appearance of the object in as much detail as possible. Can they see more detail using the optical aid or less? Why? What is the problem of observing objects in

space from Earth? Have them record their responses in their journals.

4. Lift up the window and have the students look at that same object with only their eyes. Ask them to describe the appearance of the object in as much detail as possible. How is this image different from the first time they viewed the object with the window closed? Have them record their responses in their journals.
5. Repeat step 4, but this time have the students look through the window with binoculars or a small telescope mounted on a tripod. Ask them to again describe the appearance of the object in as much detail as possible and again to record their answers in their journals.
6. Have students break into small groups and share their journal observations. Have each group share their answers with the class. Guide students' understanding that telescopes need to be in space so that we do not see a blurry image. Ask them "*Which view did they like the best?*", and then "*How could you see more detail to view the image even better?*" Student responses should discuss the need for a bigger pair of binoculars or telescope to see an object in more detail.
7. Relate the view seen with their eyes through the open window, to that of the Hubble Space Telescope. Explain to students that we need larger telescopes in space to see celestial objects in more detail. The view of the object through binoculars or a small telescope compared to the unaided view is the kind of difference that you would see with a larger telescope in space compared to a smaller one in space, such as the James Webb Space Telescope compared to the Hubble Space Telescope.
8. Break the class into two groups. One group will be the Hubble Space Telescope Team (3 or more students) and the other the James Webb Telescope Team (the rest of the class will need to be 18 students). Explain to the students that they will be making a scale model of the Hubble and the Webb mirrors.

THE HUBBLE SPACE TELESCOPE TEAM

From the Resources Section at the end of this lesson, share Hubble facts with students. Students should have the understanding that they will be sharing what they believe is important from this information with the rest of the class.

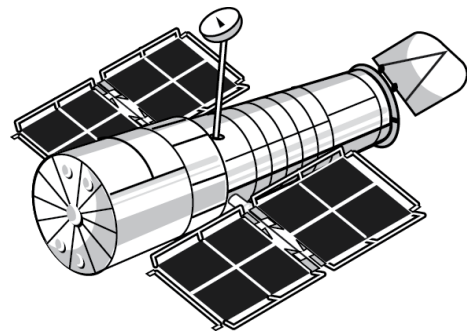

Credit: Illustration courtesy of NASA

9. Give the students an 8" x 8" sheet of cardstock and a similar size of tinfoil. Have the students use a guide to trace and then cut out a circle with a diameter of 7.3" of cardstock and tinfoil. The students should then glue the tinfoil, shiny-side-up, to one of the sides of the cardstock circle.

10. Reference the illustration at the end of this lesson that depicts the primary mirror of Hubble. The illustration shows a galaxy. Assign the students to draw the galaxy on the non-tinfoil side of their model. Have students clean up their area when finished.

JAMES WEBB SPACE TELESCOPE TEAM

As the Hubble Team begins working on their telescope model have the Webb team work on theirs. From the Resources Section at the end of this lesson, share Webb facts with students. The students should have the understanding that they'll be sharing what they believe is important from this information with the rest of the class.

11. Explain to students that they are going to be making a scale model of Webb's primary mirror. Distribute one 5" x 5" sheet of cardstock and a similar size of tinfoil to the students. They will need 18 pieces to complete the mirror model.
12. Have each student use a guide to trace and then cut out a hexagon with a diameter of 4". The students should have one hexagon made of cardstock and one of tinfoil. The student should then glue the tinfoil, shiny-side-up, to one of the sides of the cardstock hexagon.
13. Reference the illustration at the end of this lesson that depicts the 18 mirror segments of Webb. Each mirror segment shows a portion of a galaxy. Assign a mirror segment to the students so that they can draw the corresponding portion of that galaxy on the non-tinfoil side of their model.
14. Once students have completed their drawings, have them assemble the model by taping the edges of the segments together by using clear tape (this is best if done on the tinfoil side of the model).
15. Using a meter stick and some masking tape, have students create a full scale mirror segment of the James Webb Space Telescope on the floor. It needs to be a hexagon with a diameter of 1.32 meters. Make certain that students understand that this is a real-scale model of just one of the 18 mirror segments. Have students look at their Webb mirror segment model for reference. Have students clean up their area.
16. Have the Hubble Space Telescope Team show their mirror and share with the class some of the interesting things they learned about their telescope. Likewise, have the James Webb Telescope Team show their mirror and share with the class some of the interesting things that they learned about their telescope.

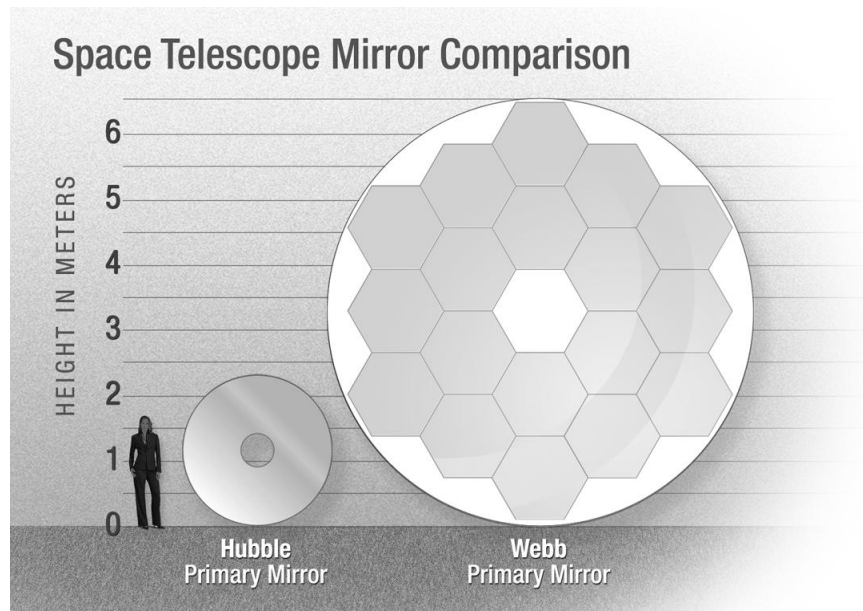

Credit: Illustration courtesy of A. Feild (STScI/AURA)

17. Have students look at the size of the mirror segment of the James Webb Space Telescope and compare it to the Hubble mirror. Have a group of students stand in a circle with a 2.4 m diameter (the diameter of the Hubble mirror). Ask them *“Why do you think the Webb is better if the Hubble mirror is larger?”* The students should understand that the Webb consists of 18 segments all working together to form a large array of mirrors with a greater light collecting area than that of Hubble. Have students look at their Webb mirror segment model for reference. Ask them *“How many Webb mirror segments could fit in the classroom?”*, *“How many classrooms would it take to create a full scale model using all 18 segments?”*

18. Have students return to their desks and take out their science journals. Ask them to think about everything they learned today and to summarize it in three to five sentences. The summary should be conversational (as if talking to a friend who is not in the class), factual (using words that they can understand), and without personal opinions (we already know it is cool – just the facts please). Students should also write a few sentences on how they think the discoveries made by Webb will affect the world and them personally. Collect science journals from students when they are finished.

Plan for Assessment:

Formative Assessment: As an informal, formative assessment, students should complete both before/after observations of the “looking through the window” portion of this lesson. Completion credit can be awarded depending on both observations made and that each student offers discussion in their journals.

Summative Assessment: Students will complete either a Hubble mirror or a Webb mirror segment portion. Students will also turn in their science journals at the end of the lesson. Students will be evaluated based on the checklist below:

- ✓ Students, in their journal, discussed why space-based telescopes are important.
- ✓ Students, in their journal, offered a meaningful summary reflection that included 3 or more points discussed in this lesson.
- ✓ Students turned in their mirror segment with a portion of a galaxy drawn on the reverse side

Materials:

- ✓ Computer and LCD projector with lesson graphics loaded on it
- ✓ Colored crayons or pencils
- ✓ Enough cardstock and tinfoil for 5” x 5” and 8” x 8” segments for the number of students outlined above (Be sure to have extra!)
- ✓ Glue
- ✓ Rulers
- ✓ Meter stick
- ✓ Science journals or other writing material for students’ reflection
- ✓ Scissors
- ✓ Set of binoculars or small telescope mounted on a tripod
- ✓ Clear tape
- ✓ Masking tape
- ✓ Water spray mister

References:

Webb: How does Webb compare with Hubble?
http://www.jwst.nasa.gov/comparison_about.html

Webb: Quick Facts
<http://www.jwst.nasa.gov/facts.html>
http://jwstsite.stsci.edu/webb_telescope/technology_at_the_extremes/quick_facts.php

Webb: Challenge: Make it big
http://jwstsite.stsci.edu/webb_telescope/technology_at_the_extremes/make_it_big.php

About the Authors:

Ryan Hannahoe is an education and public outreach intern on the James Webb Space Telescope mission at the NASA Goddard Space Flight Center. Ryan is also an elementary education student at Montana State University–Bozeman.

Peter Detterline is an instructor of astronomy at Kutztown University, and he serves as the director of the Boyertown Area School District Planetarium.

Additional resources:



Credit: Galaxy image courtesy of NASA, ESA, and the Hubble Heritage Team (STScI/AURA)

The above represents an image of a face-on spiral galaxy that appears on our Hubble mirror model. This image has been slightly altered for the purpose of this lesson and is 1 to 34 scale.

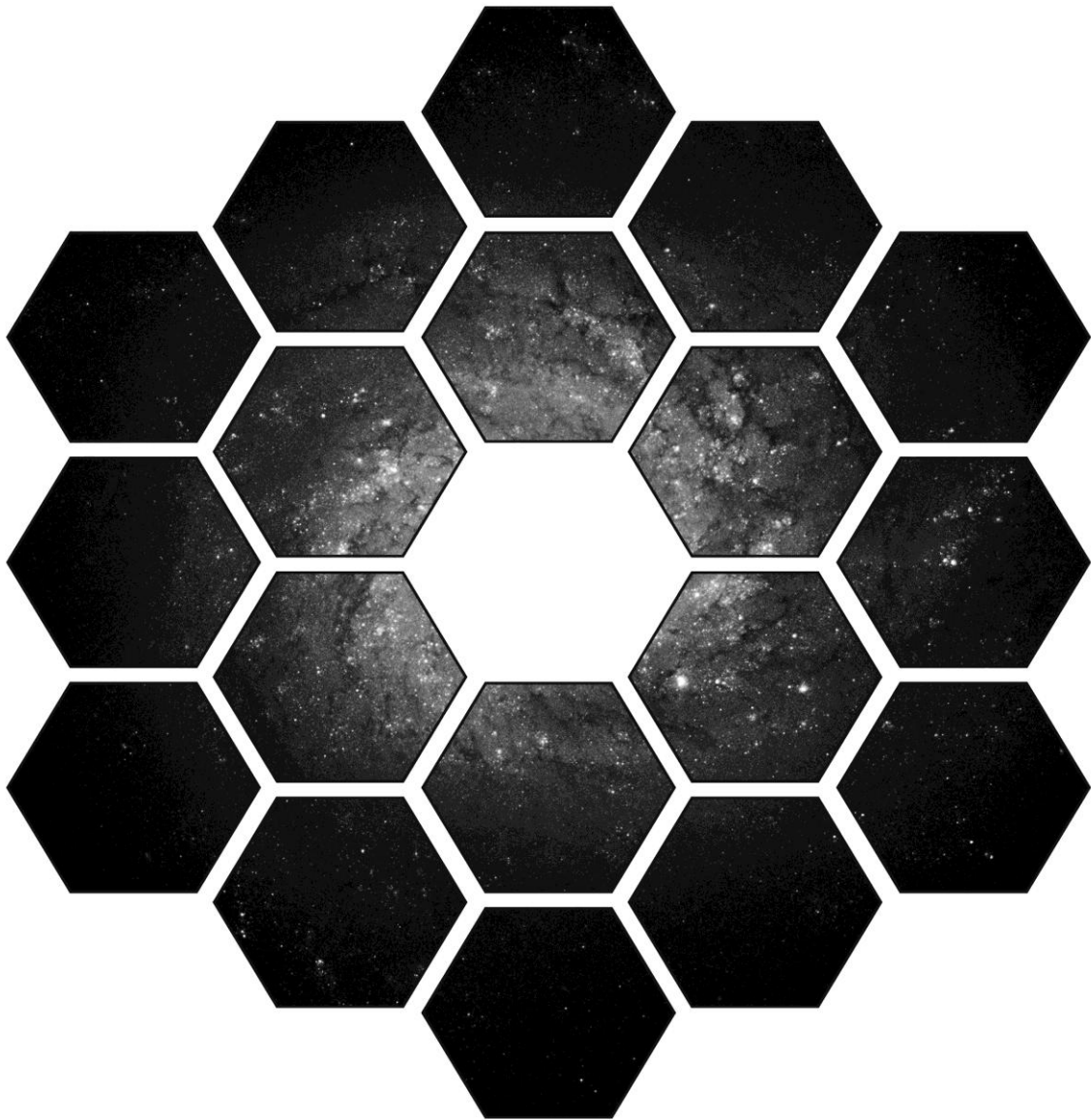

Credit: Galaxy image courtesy of NASA, ESA, and the Hubble Heritage Team (STScI/AURA)

The above represents an image of a face-on spiral galaxy that appears on our Webb mirror model; this has been slightly altered for the purpose of this lesson and is 1 to 34 scale.

Hubble Space Telescope primary mirror template (template to scale):

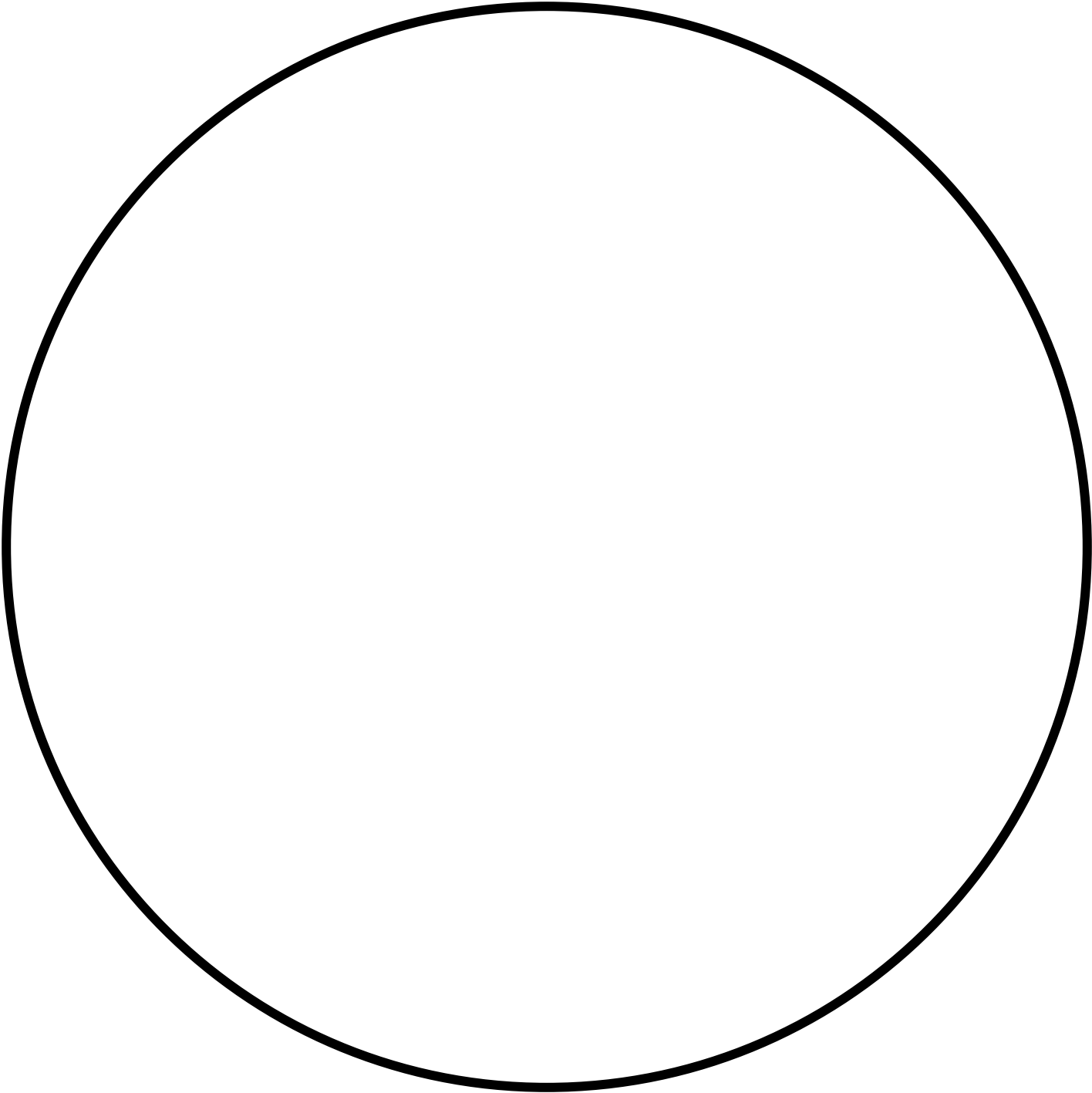

James Webb Space Telescope mirror segment template (template to scale):

